

ITEM NO.	PART NUMBER	DESCRIPTION	QTY.
1	3-897-10070	MOUNTING BOLT, 10x1.5, 70mm	3
2	3-891-306P	FULL OEM JAW REPLACEMENT SET, 6IN, 3-JAW	3
3	3-889-008P	WRENCH FOR 6IN & 8IN SCROLL CHUCK	1
4	3-886-306P	PINION FOR 6IN SCROLL CHUCK	3
5	C-CK6-BDY3JFM	CHUCK BODY, 6IN	1
6	3-809-906P	FITTING, GREASE	1
7	3-887-306P	SCROLL PLATE FOR 6IN CHUCK	1
8	3-888-906P	PINION SCREW FOR 5IN&6IN CHUCK	3
9	C-CK6-COVER	PLATE, COVER, MACHINED	1
10	3-899-310P	SHCS, M8x1.25X16	3

-CLICK ON LINK BELOW FOR REPLACEMENT PARTS-

[WWW.TOOLMEX.COM](http://WWW.TOOLMEX.COM)

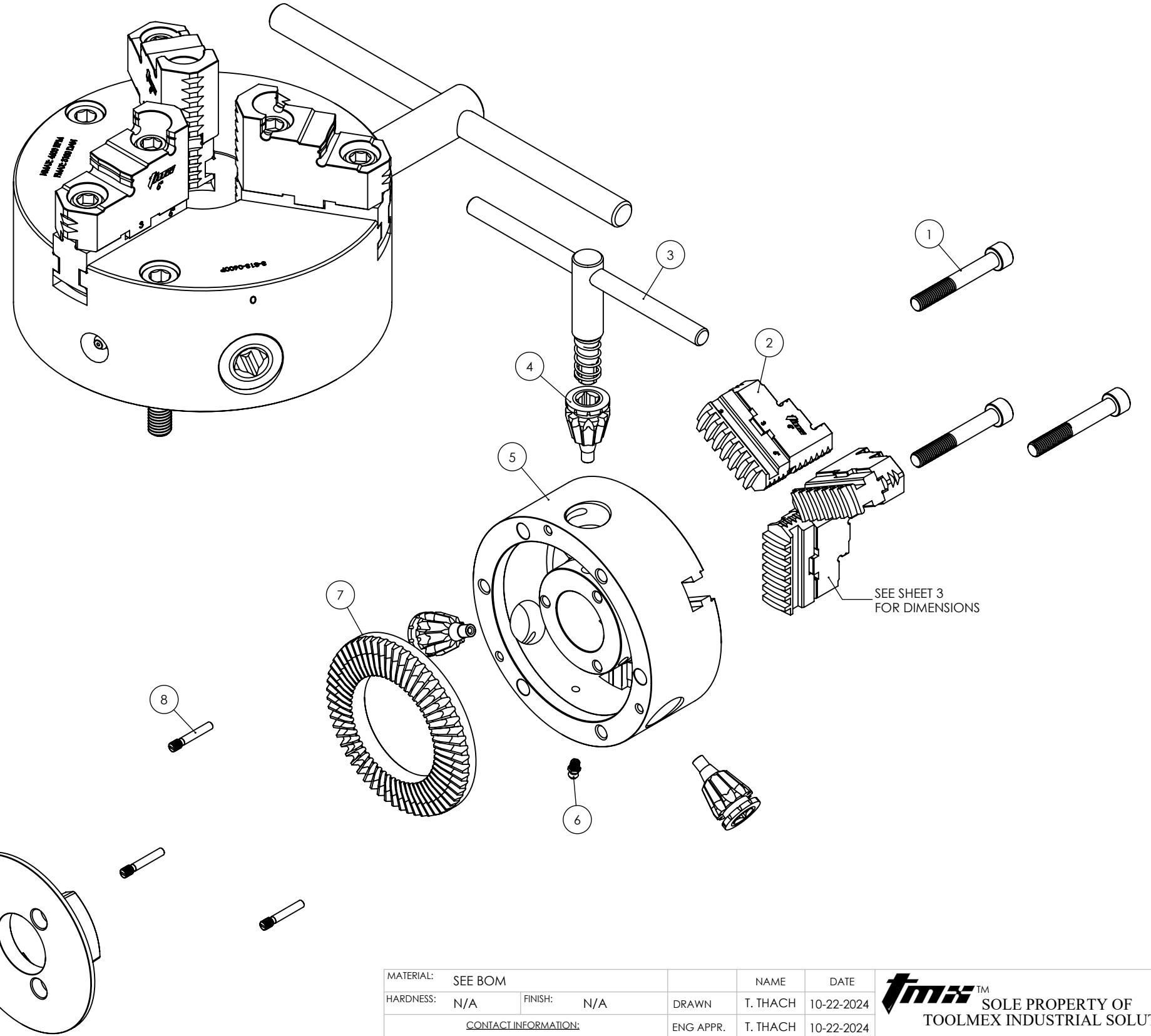

SELLING UNIT: EACH  
 CHUCK TYPE: SCROLL  
 CHUCK SIZE: 6IN  
 BODY MATERIAL: FORGED STEEL  
 NUMBER OF JAWS: 3  
 JAW TYPE: 2 PIECES  
 WEIGHT: 22 LBS  
 MOUNT TYPE: FRONT  
 GRIPPING FORCE: 3100 daN  
 SPEED: 4600 RPM Max.

MATERIAL:	SEE BOM	NAME	T. THACH	DATE	10-22-2024
HARDNESS:	N/A	FINISH:	N/A	DRAWN	T. THACH
<u>CONTACT INFORMATION:</u> Toll Free 855-869-2425 Fax 508-653-5110 www.tmxtools.com 34 TALBOT ROAD NORTH BOROUGH, MA 01532 USA			ENG APPR.	T. THACH	10-22-2024
INTERPRET GEOMETRIC TOLERANCING PER: Y1999-2001			MFG APPR.		
 THIRD ANGLE PROJECTION			Q.A. APPR.		
CONFIDENTIAL THIS DRAWING AND THESE SPECIFICATIONS ARE THE SOLE PROPERTY OF TOOLMEX INDUSTRIAL SOLUTIONS, AND SHALL NOT BE REPRODUCED, OR COPIED IN PART OR AS A WHOLE WITHOUT THE EXPRESS WRITTEN PERMISSION OF TOOLMEX INDUSTRIAL SOLUTIONS IS PROHIBITED.			SALES APPR.		
 SOLE PROPERTY OF TOOLMEX INDUSTRIAL SOLUTIONS				TITLE 6IN PLAIN BACK FRONT MOUNT SCROLL CHUCK	
SIZE DWG. NO.		REV		UNITS IN MILLIMETER	
<b>B</b> 3-813-0600P		<b>A</b>		DO NOT SCALE DRAWING	
				SHEET 1 OF 3	

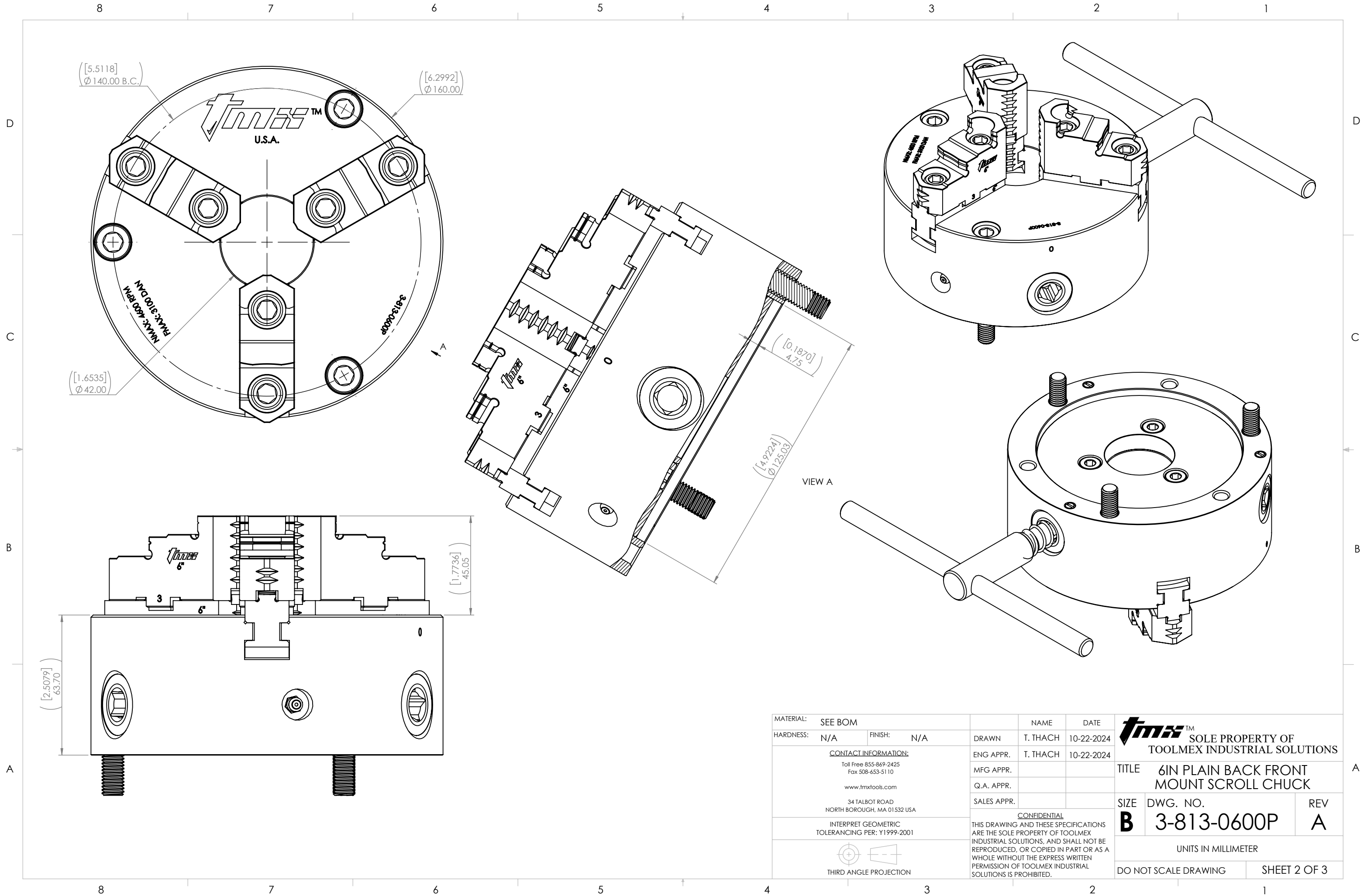

MATERIAL:	SEE BOM	NAME	T. THACH	DATE	10-22-2024
HARDNESS:	N/A	FINISH:	N/A	DRAWN	T. THACH
<p><b>CONTACT INFORMATION:</b>  Toll Free 855-869-2425  Fax 508-653-5110  www.tmxtools.com  34 TALBOT ROAD  NORTH BOROUGH, MA 01532 USA</p>			ENG APPR.	T. THACH	10-22-2024
			MFG APPR.		
			Q.A. APPR.		
			SALES APPR.		
<p>INTERPRET GEOMETRIC TOLERANCING PER: Y1999-2001</p>			<p><b>CONFIDENTIAL</b>  THIS DRAWING AND THESE SPECIFICATIONS ARE THE SOLE PROPERTY OF TOOLMEX INDUSTRIAL SOLUTIONS, AND SHALL NOT BE REPRODUCED, OR COPIED IN PART OR AS A WHOLE WITHOUT THE EXPRESS WRITTEN PERMISSION OF TOOLMEX INDUSTRIAL SOLUTIONS IS PROHIBITED.</p>		
<p>THIRD ANGLE PROJECTION</p>			<p>UNITS IN MILLIMETER</p>		

<p><b>tmx</b>™ SOLE PROPERTY OF  TOOLMEX INDUSTRIAL SOLUTIONS</p>		
<p>TITLE 6IN PLAIN BACK FRONT  MOUNT SCROLL CHUCK</p>		
SIZE	DWG. NO.	REV
<b>B</b>	<b>3-813-0600P</b>	<b>A</b>
DO NOT SCALE DRAWING		SHEET 2 OF 3

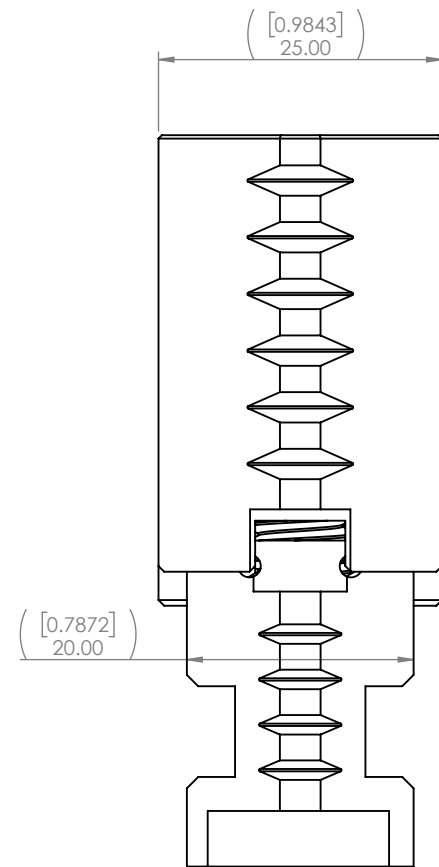
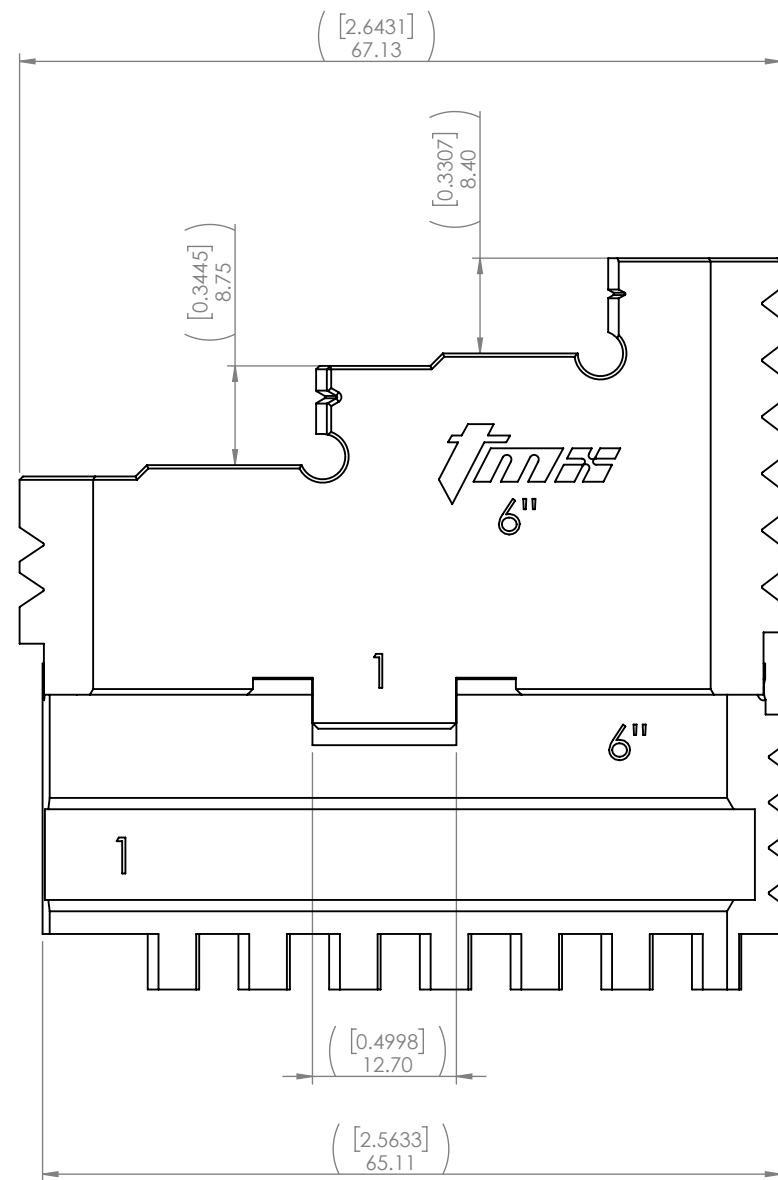
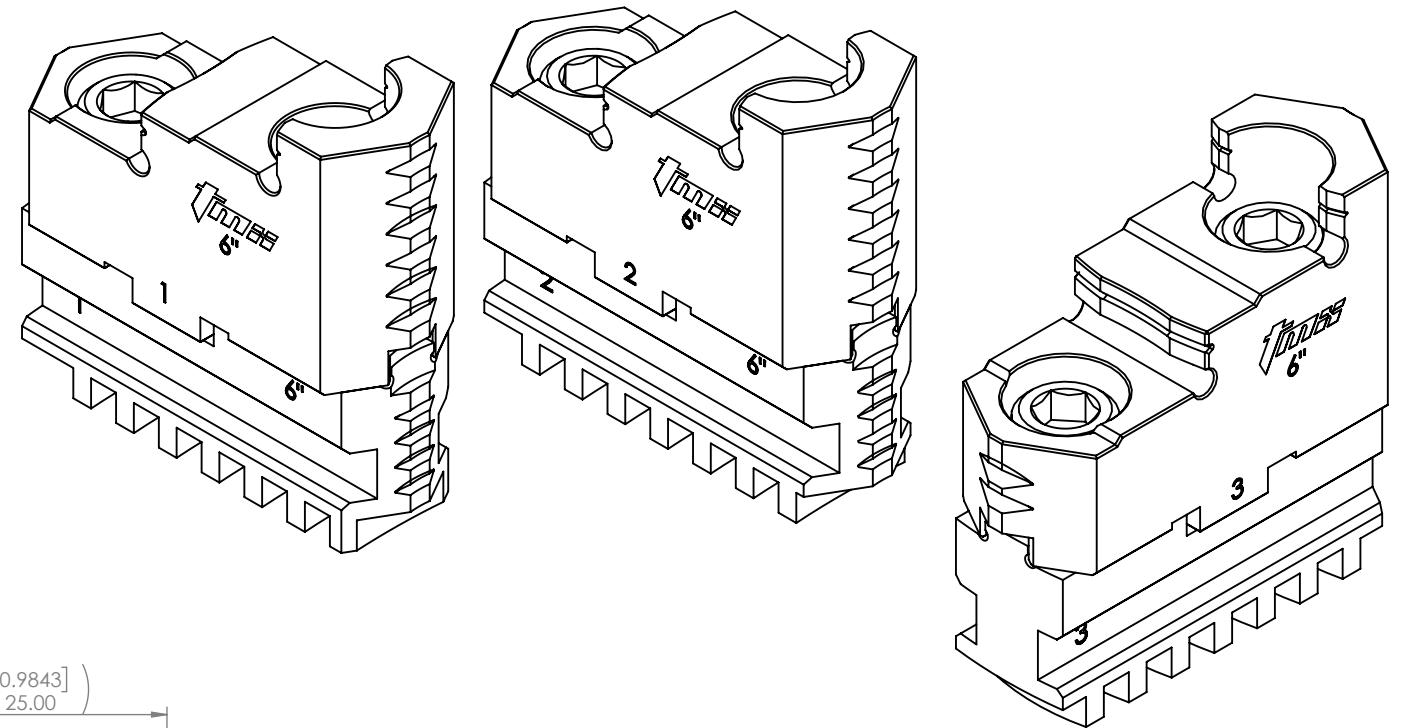
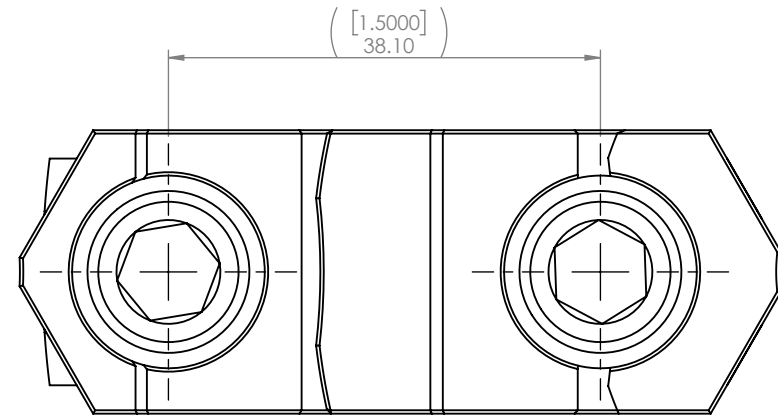

**-CLICK ON LINKS BELOW FOR REPLACEMENT PARTS-**  
[3-883-306P, HARD TOP JAWS, 6IN, 3-JAW 3 PC SET](#)  
[3-885-306P, HARD MASTER JAWS, 6IN, 3-JAW 3 PC SET](#)

MATERIAL:	SEE BOM	NAME:	T. THACH	DATE:	10-22-2024	<b>TOOLMEX™</b> SOLE PROPERTY OF TOOLMEX INDUSTRIAL SOLUTIONS					
HARDNESS:	N/A	FINISH:	N/A	DRAWN:	T. THACH		10-22-2024				
<b>CONTACT INFORMATION:</b> Toll Free 855-869-2425 Fax 508-653-5110 www.tmxtools.com 34 TALBOT ROAD NORTH BOROUGH, MA 01532 USA							TITLE	6IN PLAIN BACK FRONT MOUNT SCROLL CHUCK			
INTERPRET GEOMETRIC TOLERANCING PER: Y1999-2001							SALES APPR.:		SIZE	DWG. NO.	REV
THIRD ANGLE PROJECTION						<b>CONFIDENTIAL</b> THIS DRAWING AND THESE SPECIFICATIONS ARE THE SOLE PROPERTY OF TOOLMEX INDUSTRIAL SOLUTIONS, AND SHALL NOT BE REPRODUCED, OR COPIED IN PART OR AS A WHOLE WITHOUT THE EXPRESS WRITTEN PERMISSION OF TOOLMEX INDUSTRIAL SOLUTIONS IS PROHIBITED.			<b>B</b>	<b>3-813-0600P</b>	<b>A</b>
						UNITS IN MILLIMETER			DO NOT SCALE DRAWING	SHEET 3 OF 3	